

marbleocity™

SKATE PARK

# ASSEMBLY INSTRUCTIONS



LET'S GET THIS  
ROLLING!





Hello!

Thank you for being a Tinkineer! We've taken great care in creating the experience that you are about to embark upon. We want your build, whether performed alone or with a family member, to be something special and memorable. Hands-on fun awaits!

The kit you are about to construct is made of real wood, right here in the United States of America! Sometimes knots or other anomalies hidden in the material can cause a part to be cut incorrectly. Not to worry! If you encounter an issue that we didn't catch, visit our website and use the "Contact Us" button at the bottom of any page to let us know what you found. We'll make it right.

One of the things about a kit is that, while we've tried, we can't fully predict exactly how you will approach the build, what things you will find easy and what things you will find difficult. At the end of the day, it's important to us that you and/or your family have a wonderful experience. If you don't, it means that despite our best attempt, there may still be an instruction to tweak or an aspect of the design to improve upon.

We'd like to take this opportunity to open a two-way dialog. If you had a great experience, we want you to tell us and, of course, your friends. If you didn't, we would like the first opportunity to make things right for you. Please reach out to us using the website link and we'll get right back to you. Allow us to help - to offer a friendly construction tip or to ship a replacement part.

When you're finished, it would give us great pride to see how your completed model turned out. Share your photos, videos, and comments on our Tinkineer Facebook page and on Instagram. Tag us @tinkineer and/or contact us directly from the website.

Happy making!

Team Tinkineer

on the web @  
**TINKINEER.COM**

At Tinkineer we are constantly working to improve your maker experience. You may observe that the shape of a part differs slightly from how it is depicted in the assembly instructions.

Please keep the wooden parts in your kit away from excessive heat and humidity.

# WELCOME!

---



Hi! My name is Adam and I'm the creator of the Marbleocity® product line.

When I was a kid I loved machines, contraptions and, of course, marble ramps. I also loved building models but I found the plastic materials unsatisfying and model cement hard to work with. Today, amazing laser-cutting technology exists to craft highly detailed shapes out of wood. The real wood parts in your kit have a great tactile feel and can be assembled easily with household white glue.

The kit that you are about to build was carefully designed to be a great maker experience that you'll enjoy in and of itself. But beyond that there's a little physics and a lot of engineering experience waiting for you. The graphic novel that begins on the next page will teach you about some of the science of skateboarding. Our goal is to expose you to some introductory physics that you'll encounter when you get to high school. More importantly, the construction of the Marbleocity Skate Park will show you how you – yes you! – can build a seemingly complex machine out of simple parts. Simple parts become sub-assemblies and sub-assemblies come together to construct an amazing, working machine that you built yourself. So grab your glue and let's get started!

Adam B. Hocherman  
Chief Tinkineer

## GETTING HELP FROM OUR COMMUNITY

Have a question about a step you're working on? Need a video tutorial? We're building a community of Tinkineers – just like you! Please visit us online at [Tinkineer.com/community](http://Tinkineer.com/community).

## LEARNING MORE

Today you'll be learning about projectile motion and centripetal force. You'll see these concepts again, most likely in your introductory high school physics class. With Marbleocity our goal is to expose you to the high-level concepts so that when you get to the classroom, the subject matter is familiar. If you'd like to learn more, on your own, there are great resources available on the web. If you're looking for a place to get started, check out Khan Academy at [khanacademy.org/science/physics](http://khanacademy.org/science/physics).

## A NOTE ABOUT SAFETY

The kit that you are about to assemble is designed for children and adults ages 12+. It contains marbles and other small parts that can be a choking hazard for children under 3 years old. If you have younger siblings or other small children living in your household, please keep these small parts safely out of their reach.

# TABLE OF CONTENTS

---

Introduction.....	3
“Skate Park Lark” .....	4
Assembly Instructions.....	12
Next Steps! .....	26

---

# LET'S DO THIS!



Hope you enjoyed the Tinkineer's day and that you picked up a little physics along the way! Now it's time to build the real thing and see those principles in action. The "build" is designed to be performed in five, one-hour sittings.

The "days" are designed to allow glue to dry at critical points so that your final result comes out perfectly. Don't be afraid to take your time! What you're building is not only fun to look at – it's a machine that really operates! Take time to make sure that tabs are fully inserted into slots and that mating surfaces are flush. Follow the tips on this page to achieve a great finished product!

## READY TINKINEER?

For this project you'll need:



Elmer's® Glue-All® Multi-Purpose white glue.\* A good, household white glue is the best glue for the job – it's easy to work with, makes a strong bond in 20-30 minutes, and dries perfectly clear so your finished marble machine will look great!



Wax paper. Scavenge a sheet of wax paper from your kitchen – it's the perfect work surface. Household white glue will not stick to it and you'll avoid mom's wrath by protecting the kitchen table.



Round toothpicks. These are perfect for applying glue. Make a puddle on your wax paper work surface and use the tip and/or edge of a toothpick to apply glue to your wood parts.



Wax candle. A wax candle is used to lubricate wood bearing surfaces that rub against one another.



## TIPS ON TECHNIQUE >

Check [Tinkineer.com/community](http://Tinkineer.com/community) for helpful videos.

### Test Fit First!



Most steps can be test assembled without any glue at all! Check your part fit and marble operation first and then apply glue second.

### Applying Glue to Flat Surfaces



Use glue sparingly – you don't need a lot! Wipe away excess glue using your finger or the edge of a clean toothpick.

### Applying Glue to Perpendicular Parts



Lay glue into corners like these using the edge of your round toothpick. In this way, you can test-fit first and add glue second.

### "Check Square"



In engineering the word "square" means "at ninety degrees". Check square, using the included tool, any time you are assembling perpendicular surfaces like these.

## BREAK SOMETHING? NEED A REPLACEMENT PART?

Marbleocity is a natural wood product! Sometimes a hidden knot can slip past our quality control gurus. If you need a replacement part contact us at [Tinkineer.com](http://Tinkineer.com). Please have your batch code handy, which is located on the paddle wheel bracket, part #37.

603231

(example only)

\* Elmer's® Washable School Glue will bond but Glue-All® is recommended for the best experience. Do not use glue sticks or generic products.

# HERE ARE THE PARTS!

All of the wooden parts required to create your Skate Park are pictured on this page. If you have trouble identifying a part during the build, you can check it here.

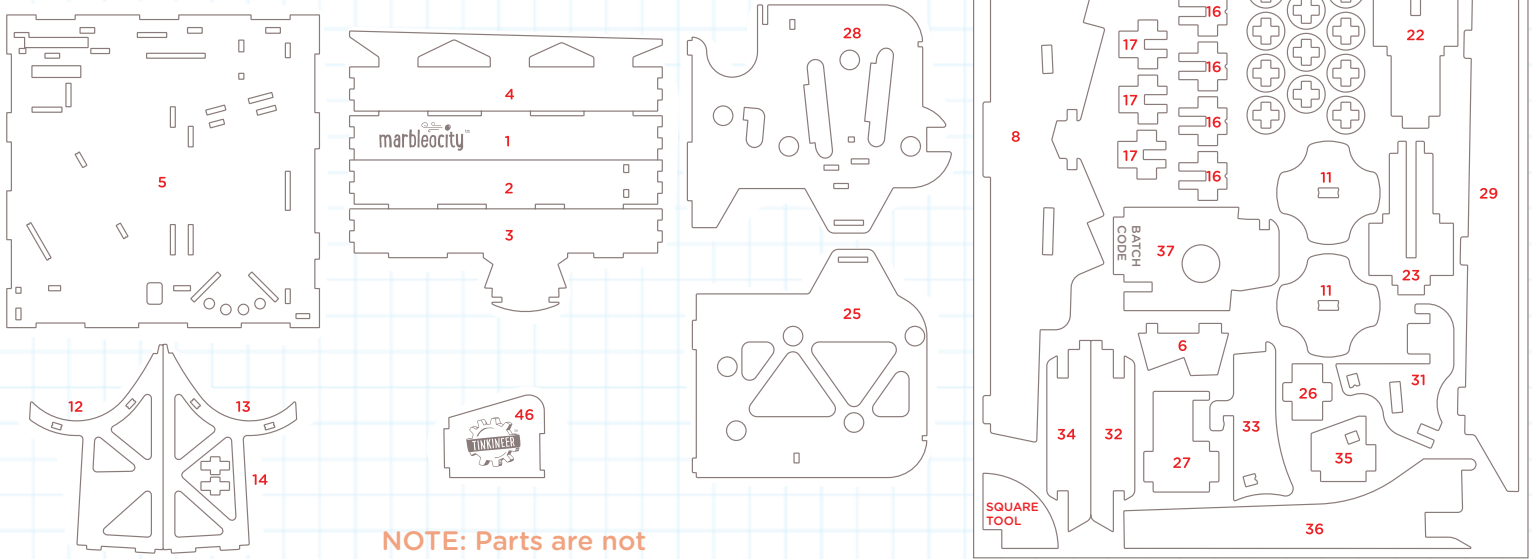

**NOTE:** Parts are not drawn to scale.

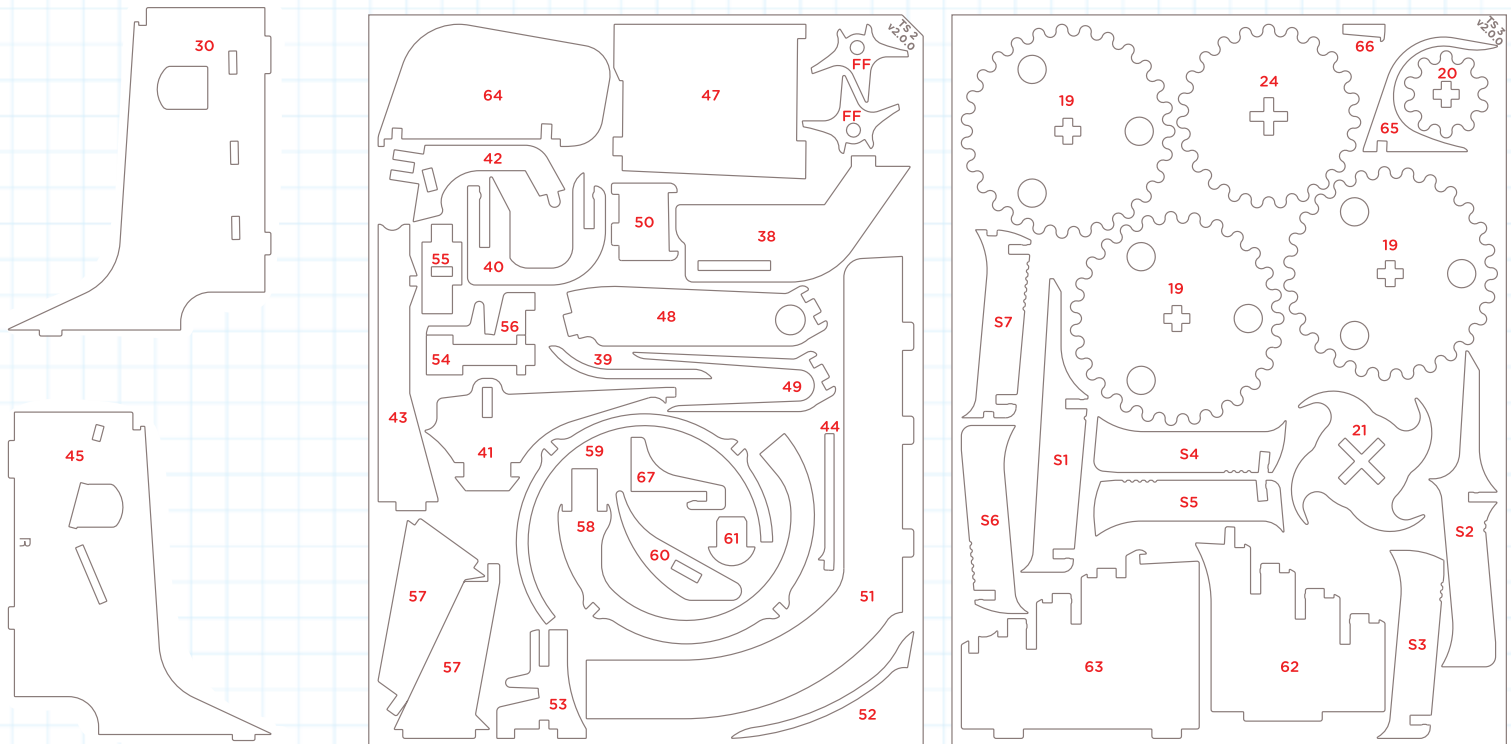

# DAY 1

ALLOW  
60 MINS



For the first few steps, we'll show you exactly where to add glue, highlighted in yellow.



NEED  
HELP?

See troubleshooting tips and helpful videos at [tinkineer.com/community](http://tinkineer.com/community).

## LET'S GET STARTED!

### PREPARATION

Spread a sheet of wax paper over your work surface. Make a small puddle of white glue, about the size of a dime, to work from. Remember, a little glue goes a long way — use a toothpick to apply it.

Most wooden parts are contained in sheets by tiny tabs. Apply even pressure with your thumbs until the parts pop free. If a small bump remains where the part was attached, use an emery board (nail file) to smooth it down.

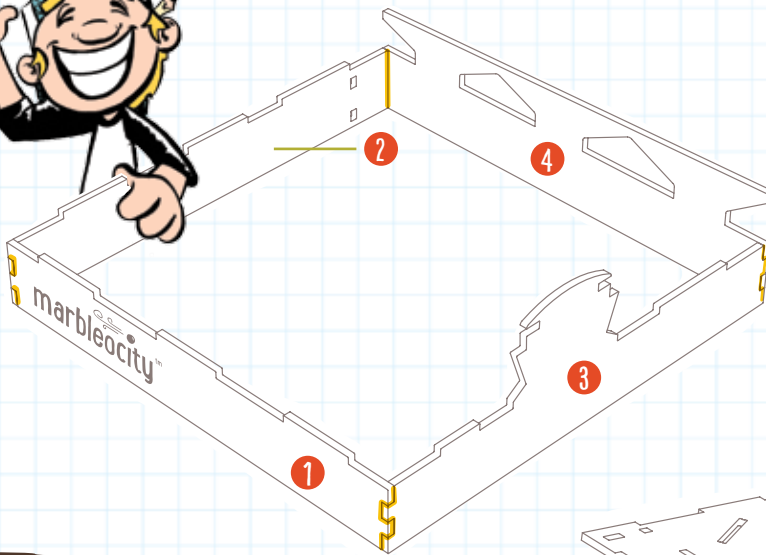

### STEP 1

#### PLATFORM

First, glue the platform front [1], sides [2,3], and rear [4] together as pictured above. This assembly is called the “skirt”.

Next, apply glue and then lower the platform top [5] down onto the skirt. Place a heavy textbook on the platform and then visually inspect all adjoining surfaces to ensure they are tight and flush! Use your finger to wipe away any excess glue.

Set the platform assembly aside to dry for 30–60 minutes. If you like, you can skip ahead to steps 4 and 5 while you're waiting.



TIP ✓

Insert the back edge of the platform first.

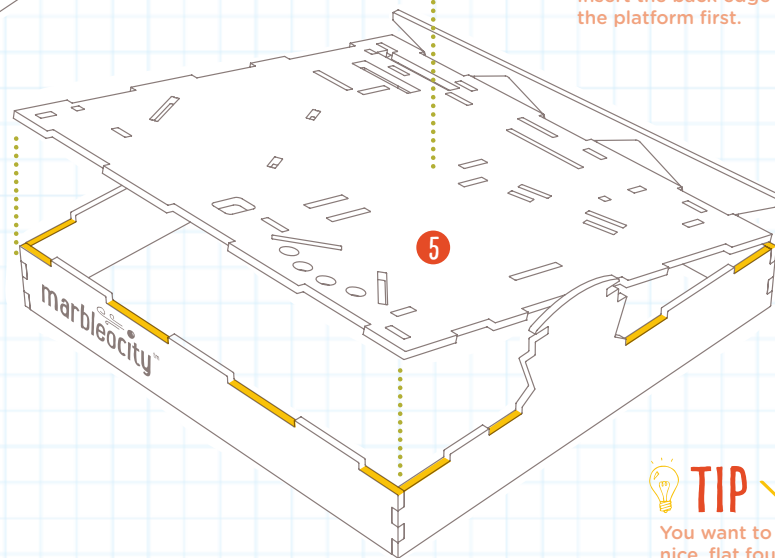

TIP ✓

You want to create a nice, flat foundation for your model. Use a heavy textbook and let your platform dry for 30-60 minutes.

## STEP 2

### BRACKETS

You'll need some infrastructure to hold the other parts of your skate park. Glue bracket [6] to the platform followed by parts [7] and [8].

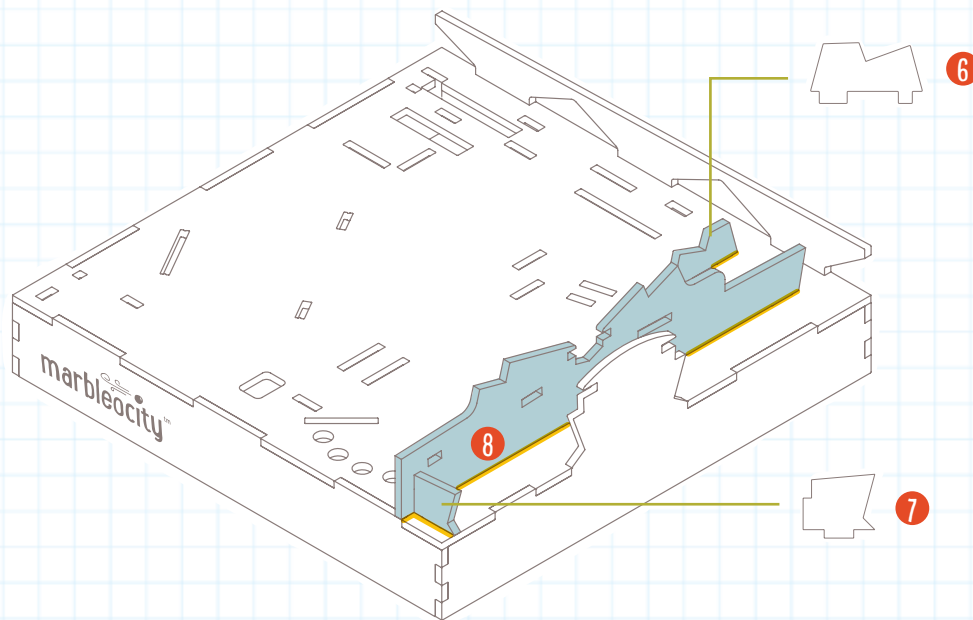

Use your 90 degree right-angle tool to ensure that all parts are "square" to the platform. You should use this tool to check all of your work in this and future steps!

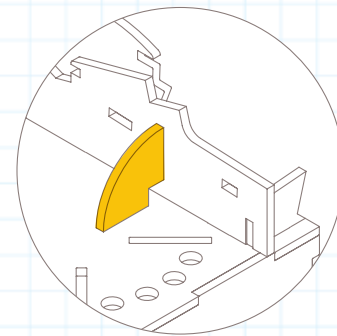

## STEP 3

### RETURN RAMPS

Install ramps [9] and [10]. If there is any play, try to minimize the gap where they come together in the middle.

Ensure all parts are square, part #8 especially. See the tip above.

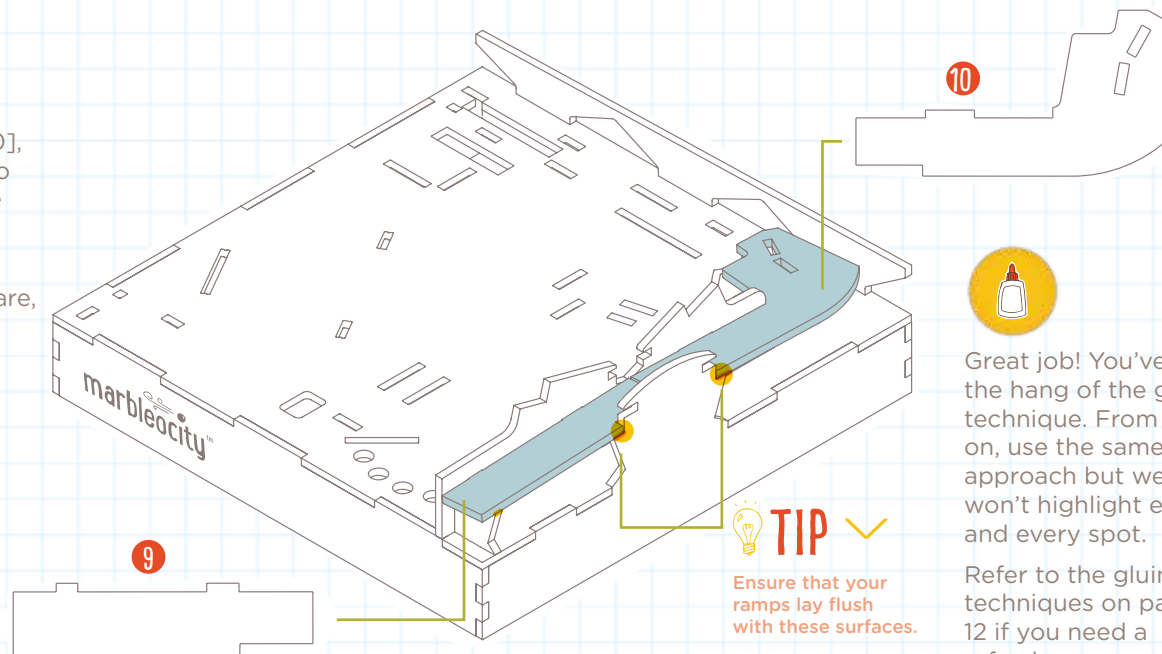

Great job! You've got the hang of the glue technique. From here on, use the same approach but we won't highlight each and every spot.



Ensure that your ramps lay flush with these surfaces.

Refer to the gluing techniques on page 12 if you need a refresher.

## STEP 4

### DRIVE KNOB

Assemble the two halves of your drive knob [11]. Ensure that the knob edges and center holes align perfectly.

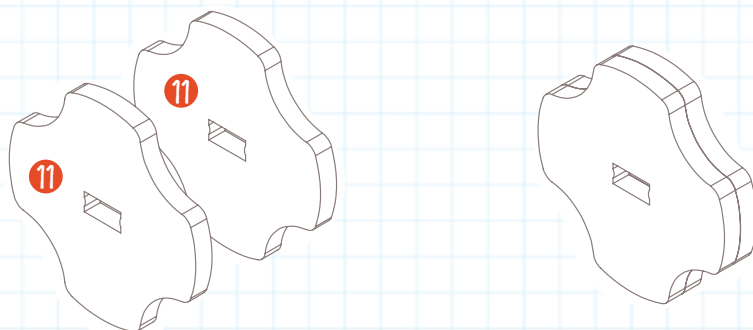

{COMPLETE!}



**NEED  
HELP?**

See troubleshooting tips and helpful videos at [tinkineer.com/community](http://tinkineer.com/community).

SET THE COMPLETED DRIVE KNOB ASIDE TO DRY. YOU'LL INSTALL IT AT THE VERY END OF THE BUILD, ON DAY 5 ...



## STEP 5

### JUMP

Construct your jump as shown. Start by laying the jump rear [13] flat on your work surface. Install cross braces [14 x2] and then drop the jump front [12] on top.

Pick up your assembly and trial-fit it to your platform without glue (see p. 23 for jump location). If it fits then you know you've assembled this correctly! Leave it in place to dry (do not glue it to the platform at this time). You won't need it again until Day 4.



**TIP** ✓

Notice that the jump front differs from the rear!

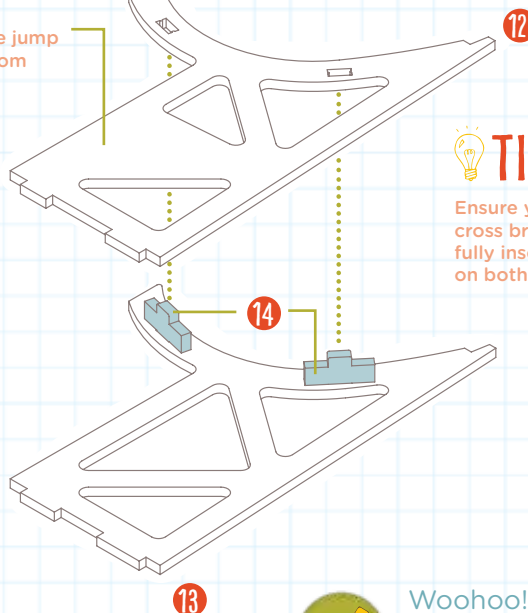

**TIP** ✓

Ensure your cross braces are fully inserted on both sides.

{COMPLETE!}



Woohoo! Day one build is in the books! Allow your parts to dry overnight. Tomorrow you'll build all the gears required for your marble lift.



# DAY 2

 ALLOW  
60 MINS



Notice this notch  
which helps  
differentiate part  
#16 from part #17.

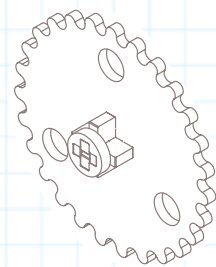
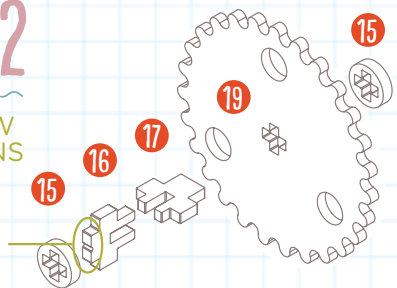

{COMPLETE!}

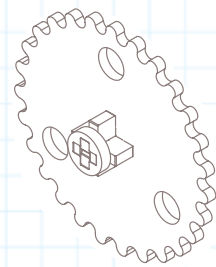
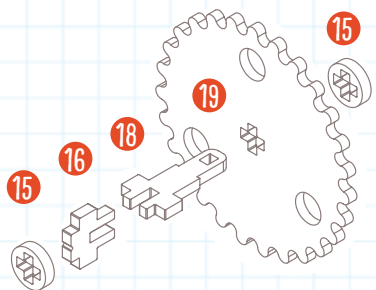

{COMPLETE!}

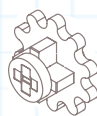
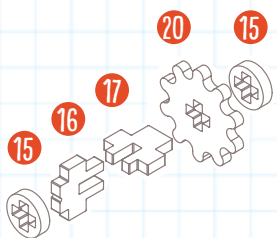

{COMPLETE!}

## STEP 1

### GEARS

X2

There are four gears to assemble in this step ... notice that you will make two copies of the topmost assembly. All the gears go together the same way. Build them one at a time and use glue sparingly. **IMPORTANT:** Take care not to let excess glue dry on or around the bearing surfaces [15].

We'll use the topmost gear as an example. Begin by assembling your axle [16 to 17]. Next, slide gear [19] onto your completed axle. Finally, glue your bearings [15 x2] onto either side to complete your gear assembly. Use your thumb and forefinger to "clamp" the final assembly together, for a moment, to ensure that everything dries square and tight.



Your bearings [15] are what rotate in the brackets you'll soon build. Ensure that no glue dries on or around your bearing surfaces (highlighted in orange, at left) or in the crevices where your bearings attach to the rest of your gear assembly.

## STEP 2

### PADDLE WHEEL

Create your paddle wheel assembly using a method similar to the above. Begin by assembling your axle [22 to 23]. Next, slide gear [24] and paddle [21] onto your completed axle, noting the orientation of the paddle, as shown. Use your fingers to apply pressure (see arrows below) to ensure that these parts dry square. Finally, glue your bearings [15 x2] onto either side to complete your paddle wheel assembly.

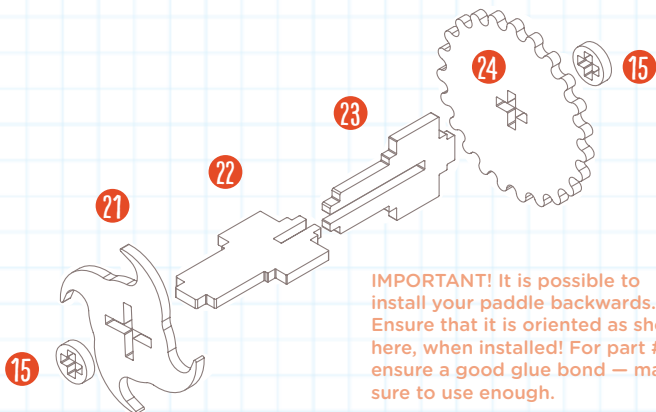

**IMPORTANT!** It is possible to install your paddle backwards. Ensure that it is oriented as shown here, when installed! For part #21, ensure a good glue bond — make sure to use enough.

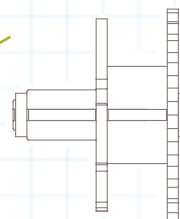
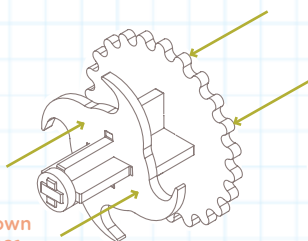

{COMPLETE!}

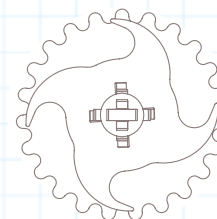

## STEP 3

### GEAR TRAIN

Now you're going to assemble your gear train! Begin by laying rear gear train bracket [25] flat on your work surface. Apply a small amount of glue to the two interior brackets [26, 27] and install as shown, checking square.

Lubricate! Using a wax birthday candle, apply wax to all bearing surfaces and the holes into which they insert! Hang the right side of bracket #25 over the edge of your table such that the gear with the long shaft can be inserted (note its specific location). Place the remainder of your gears (no glue!) as shown. They should mesh cleanly and turn easily if moved with a finger.

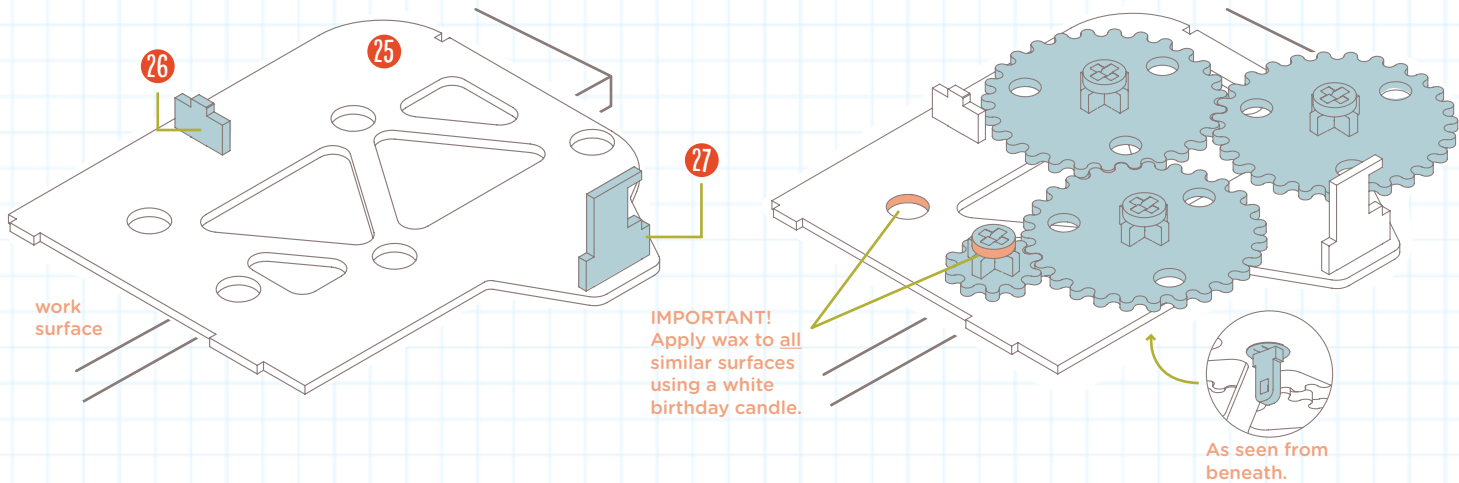

## STEP 4

### GEAR TRAIN, CON'T

If you haven't done so already, apply wax to the holes in your gear train front bracket [28]. Lower the bracket down into place and apply a little pressure with your fingers, at the locations shown by the arrows, while the glue sets up for a few moments.

APPLY PRESSURE WITH YOUR FINGERS, AT THE LOCATION OF THE GREEN ARROWS.

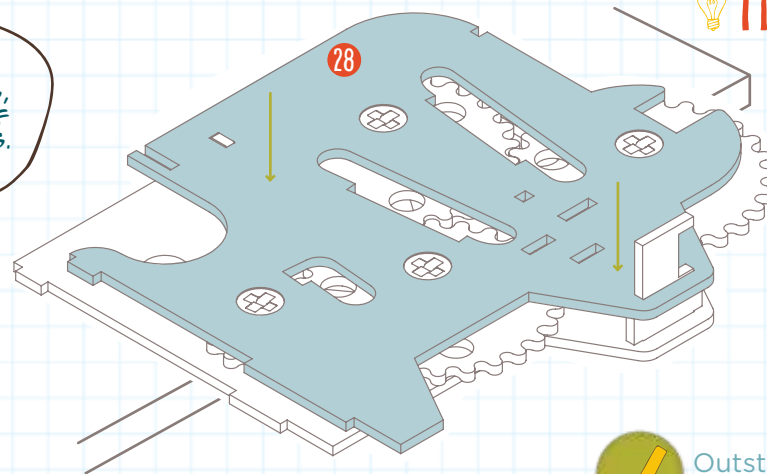

Ensure that your bearing surfaces are smooth. If a small wood "bump" remains where a bearing was removed from a wood sheet, file or sand it smooth.



Outstanding! That's the end of the day two build. You've completed your gear train and tomorrow you'll install it to the platform!

## STEP 1

### GEAR TRAIN INSTALLATION

Add your interior rear return rail [29] to the model. Next, carefully pick up your gear train by pinching it with two hands at the locations of the interior brackets. Tack it into place on the platform using a few small dabs of glue. Now check that rear rail #29 is flush up against the rear of your gear train.

No time for a sandwich! Proceed immediately to the Step 2 because parts you will add next will hold your gear train in the proper location.

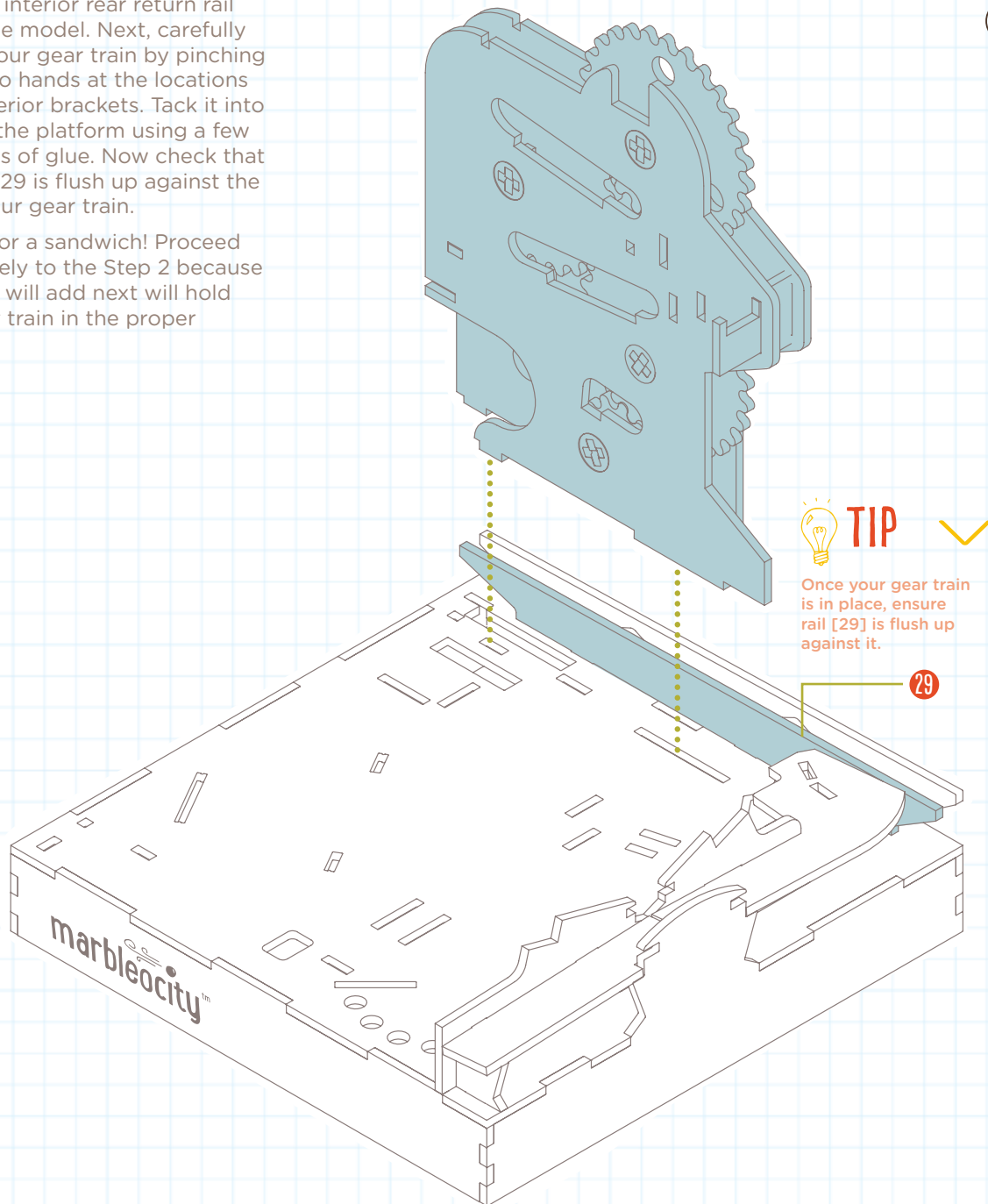

# DAY 3

⌚ ALLOW  
45 MINS

## STEP 2

### RAIL SLIDE DESCENT

Install the left rail slide descent [30]. Notice that the slots in the platform are longer than the tabs on this part. Lower the rail down to the platform and then slide it towards the gear train until it seats in place. Using your tool, ensure that the gear train is perfectly square to the platform.

Next lower top bracket [31] into place and then install the upper safety rail [32]. You'll need to first angle it into the hole in the top bracket (a slight press fit) and then seat it into place.



**TIP**

When installed correctly, safety rail tilts toward the rear of the model.

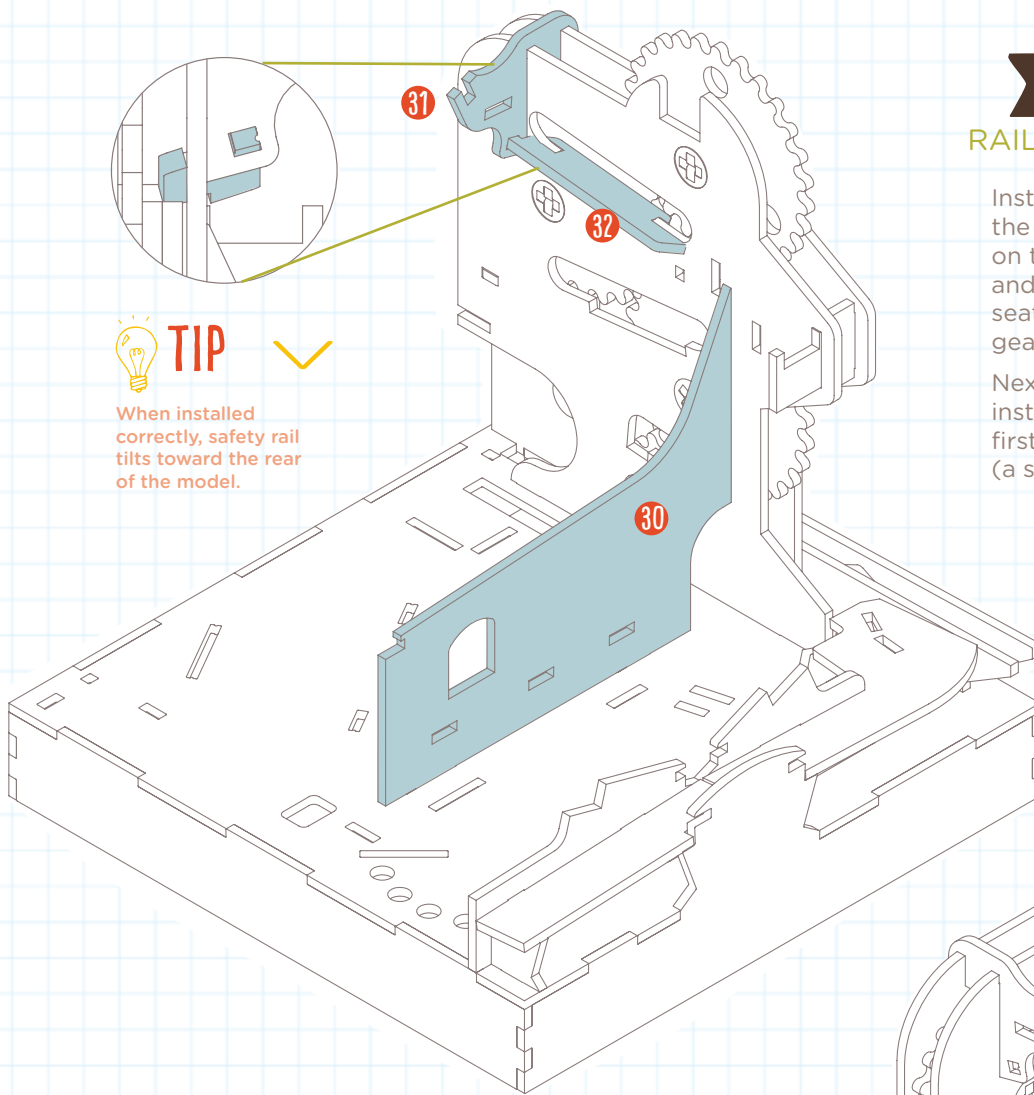

## STEP 3

### MORE RAMPS!

Install vertical bracket [33] and lower safety rail [34]. The lower safety rail installs the same way that you installed the upper safety rail in Step 2. It also tilts toward the rear of the model.

Next, add bracket [35] and return ramp [36] to your model. The far edge of the return rail rests on bracket #6 (not seen in this diagram), which you installed way back on Day 1, Step 2. Ensure bracket #35 is square and that ramp #36 is flush against it.

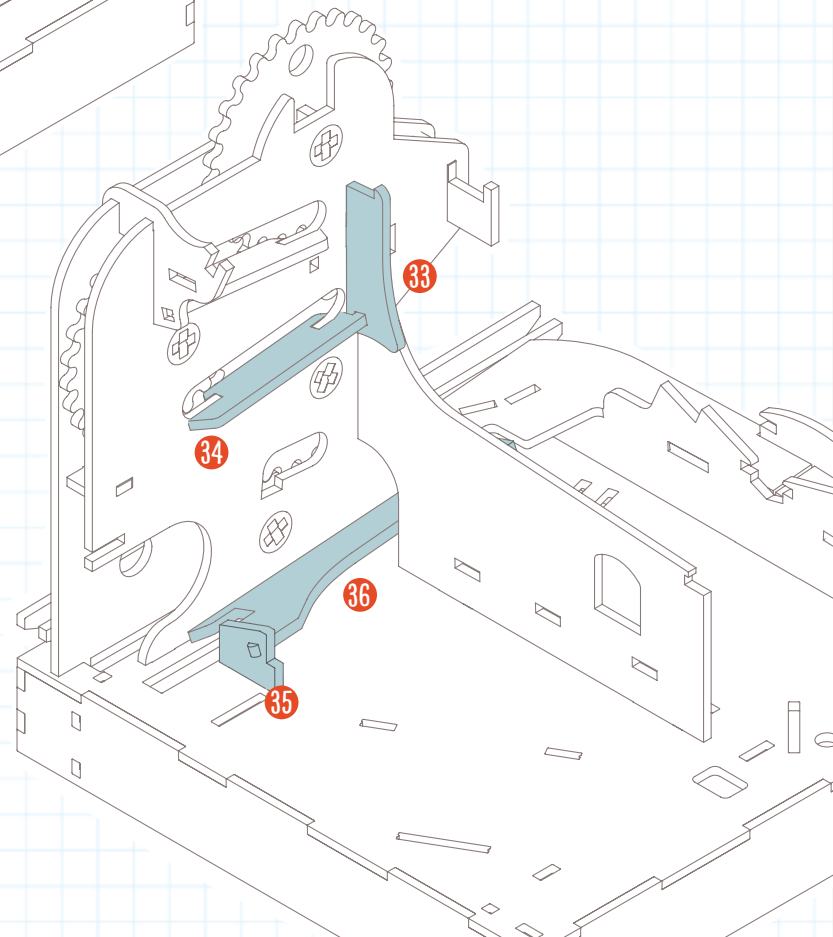

## STEP 4

### INSTALL PADDLE WHEEL



The candle wax may be a little tacky at first - your gear train will break in with use. However, you should not feel severe resistance. If that's the case, remove your gear train before the glue sets and fix any other issue. Perhaps one of your gear assemblies did not dry square.

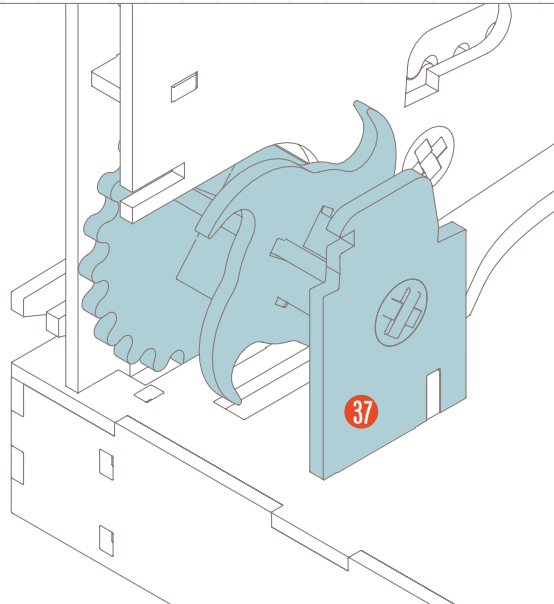

If you haven't done so already, wax the bearing surfaces on your paddle wheel assembly. Also add wax to the hole in paddle wheel bracket [37].

Maneuver your paddle wheel assembly into place — you may need to spin the gear train slightly to get the large paddle wheel gear to mesh. Next, “fold” bracket #37 up and into its final location. Hold the bracket in place with one hand and test operation of your gear train by gently spinning it with your other hand - it should move freely. If all looks good, lightly glue your bracket in place and ensure it is square with the platform.

## STEP 5

### FEEDER RAMP

Using small dabs of glue, add feeder ramp [38] and feeder ramp rail [39]. Ensure the feeder ramp sits flush to the gear train wall (see highlighted area).

Finally, slide safety rail [40] into place as shown. It's a slight press-fit. No glue required! If you need to access your paddle wheel assembly later, you can easily remove this part.

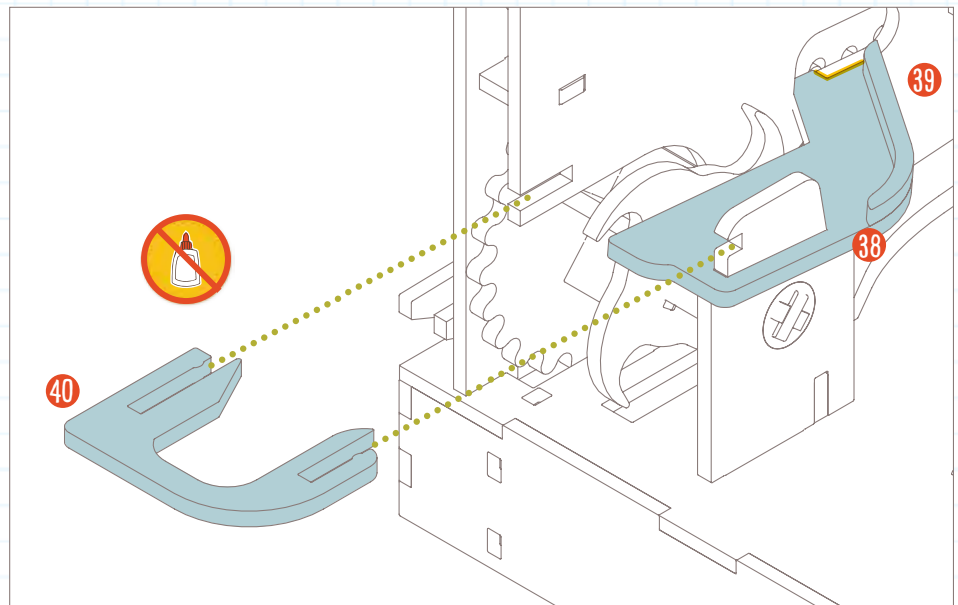

Sweet! Day is done! Before closing up shop, check square of all newly installed parts. You want to ensure that everything dries nice and straight, overnight. We'll resume work tomorrow!

# DAY 4

 ALLOW  
60 MINS

## STEP 1

### RELEASE RAMP

Construct your upper release ramp from the two parts [41, 42] shown. Set aside to dry — you'll add it to your model in a moment.

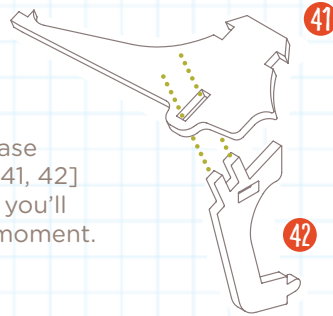

{COMPLETE!}

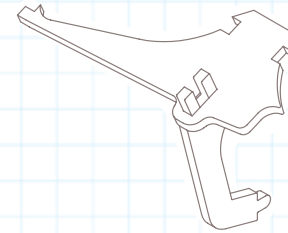

## STEP 2

### EVEN MORE RAMPS!

Install your dump truck descent ramp [43] as shown.

Next, install the release ramp assembly you just built in Step 1. Lower it into place from above and add its rail [44]. The tab on part #42 inserts into the small hole on the front gear train bracket. See the inset for a final view of the installed assembly.

Finally, install the right rail slide descent [45] and add the trough [46, 47].

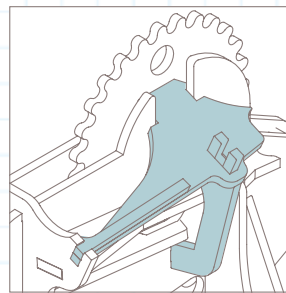

Installed view

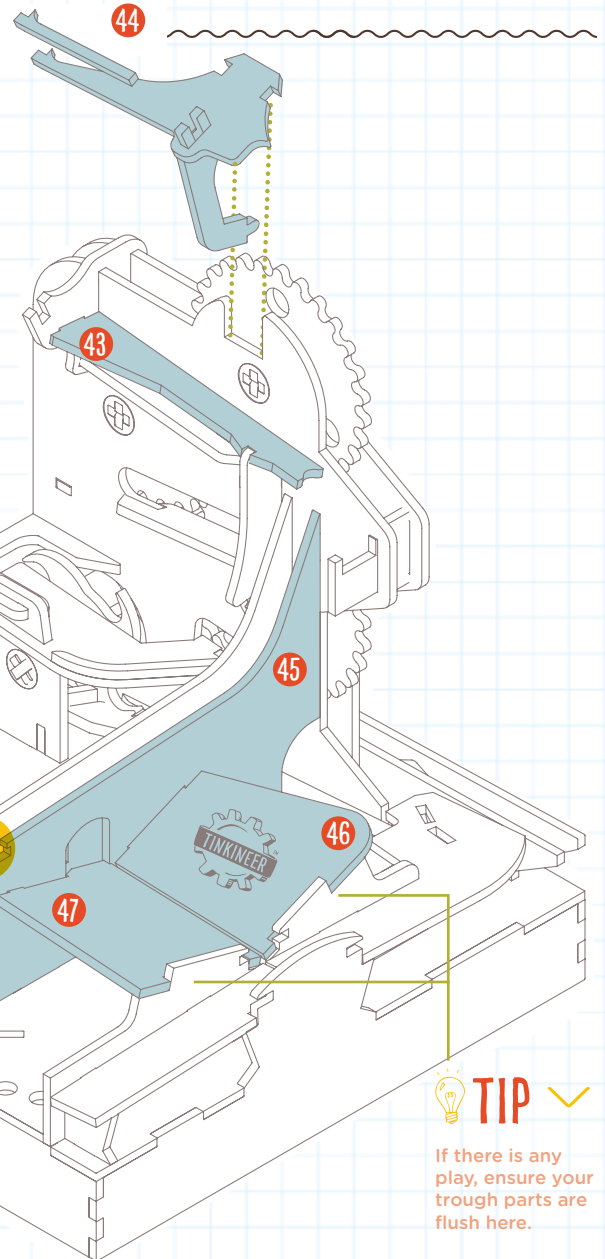

## STEP 3

### FLIP-FLOP

Construct your flip-flop from two identical parts [FF x2].

Don't install this part right now; just set aside for later.

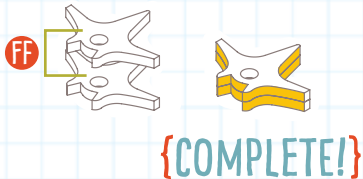

TIP

IMPORTANT: Ensure that the two parts of your flip-flop align perfectly with one another, especially the hole!



TIP

It may be helpful to temporarily insert part #58 (see p. 24) to hold rail spacing while drying.



TIP

If there is any play, ensure your trough parts are flush here.

## STEP 4

### INSTALL JUMP

Glue your completed jump into place. Add its feeder ramp [48] and rail [49]. Ensure alignment of all adjoining parts and that jump is fully seated. Later, if your marble doesn't make a perfect landing, poor alignment here could be the cause.

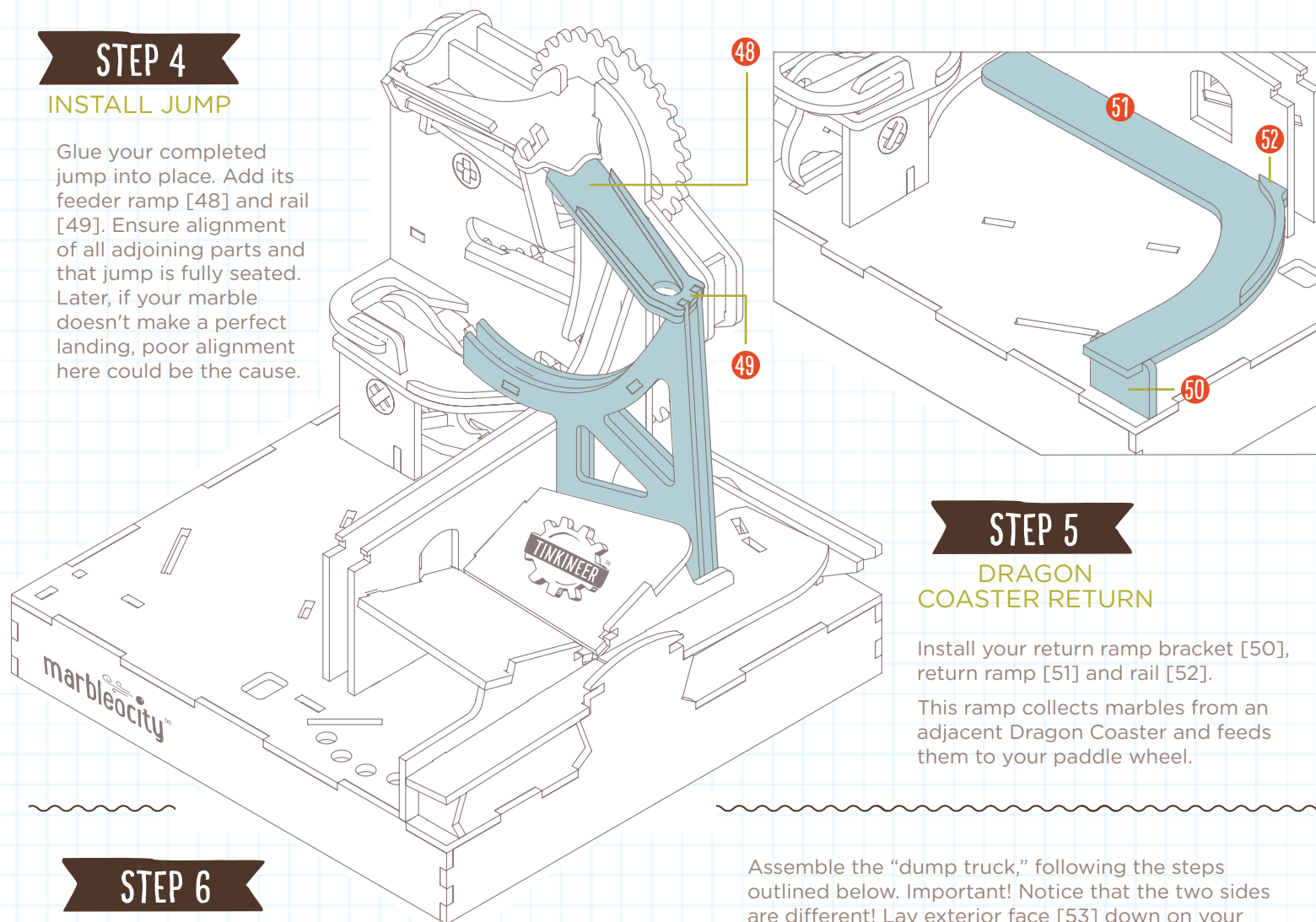

## STEP 5

### DRAGON COASTER RETURN

Install your return ramp bracket [50], return ramp [51] and rail [52].

This ramp collects marbles from an adjacent Dragon Coaster and feeds them to your paddle wheel.

## STEP 6

### DUMP TRUCK

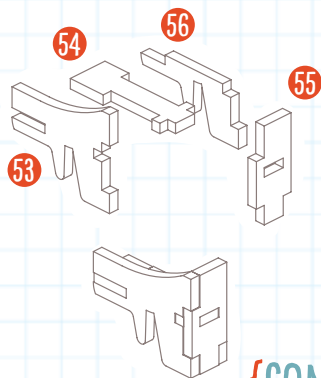

Two marbles collect and then a third marble dumps the "dump truck." You can add a little modeling clay, under the nose, if you need to tune the operation.

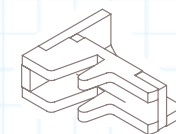
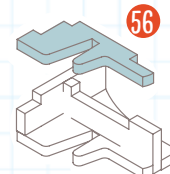
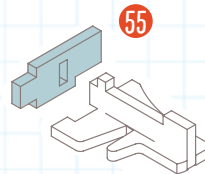
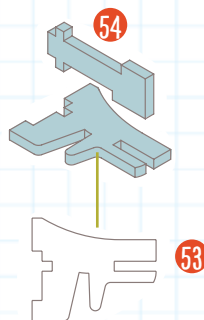

**{COMPLETE!}**

Assemble the "dump truck," following the steps outlined below. Important! Notice that the two sides are different! Lay exterior face [53] down on your work surface first and ensure it is oriented as shown below! Test assemble all parts before gluing!



Nice! You've completed the day four build! One more to go.

**{COMPLETE!}**

# DAY 5

 ALLOW  
45-60 MINS

## STEP 1

### RAIL SLIDE

Install the rail slide uprights [57 x2], rail slide surface [58] and its safety rail [59].

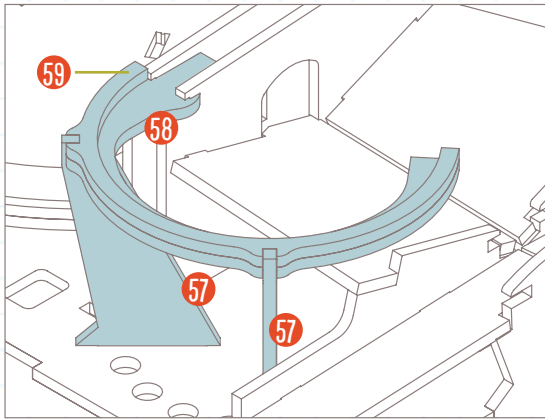

## STEP 2

### REAR DIVERTER

Construct your rear diverter from two parts [60, 61] as shown. Set it aside to dry.

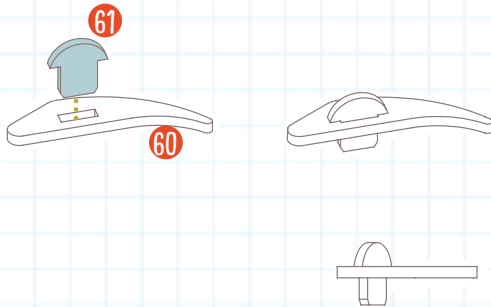

{COMPLETE!}

## STEP 3

### STAIRS

Cool! It's time to assemble your staircase. Notice that your stairs have little notches which will help you identify the correct parts. Stair #1 is at the bottom and Stair #7 is at the top.

Begin by installing your staircase uprights [62, 63] to the platform.

Next, drop in bottom stair #1 [S1] and top stair #7 [S7]. Ensure they sit all the way down in their slots.

Finally, add the platform [64] and its safety rail [65]. Ensure there is no gap between the underside of part #64 and the uprights! Hold it down flush, while drying, if you need to.

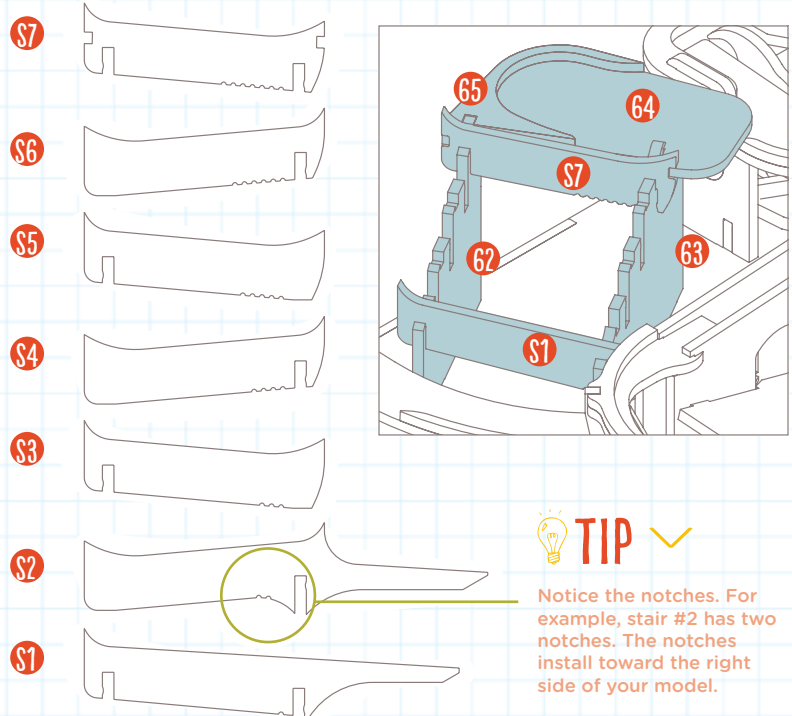

Now complete the staircase! Test fit the remaining stairs [S2-S6] without glue. Place a marble at the arrow and ensure it rolls all the way down to the trough. If it doesn't, ensure your stairs are fully seated. Now apply glue! If there's any wiggle, lean them toward the rear of the model to dry.

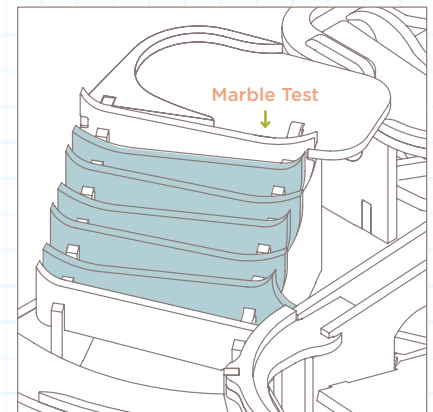



## STEP 4

### FINAL TOUCHES

No glue is required for this step! Drop your flip-flop, dump truck and two diverters (from today's Step 2 and part #67) into place in the locations shown. On the backside of your model, slip your drive knob onto the shaft and secure it in place with peg [66].

You're ready to skate! Drop a few marbles into the trough. Turn the drive knob clockwise (as seen from behind) and watch your creation come to life!



**TIP** ✓

If your flip-flop has excess friction, apply candle wax to the adjoining surfaces.

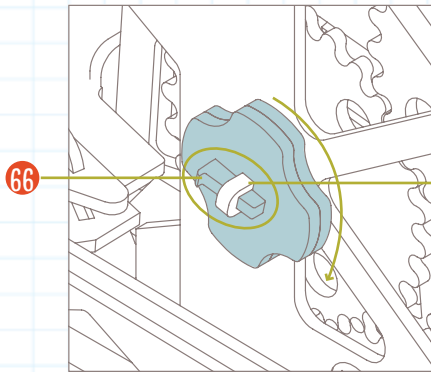

As seen from behind.

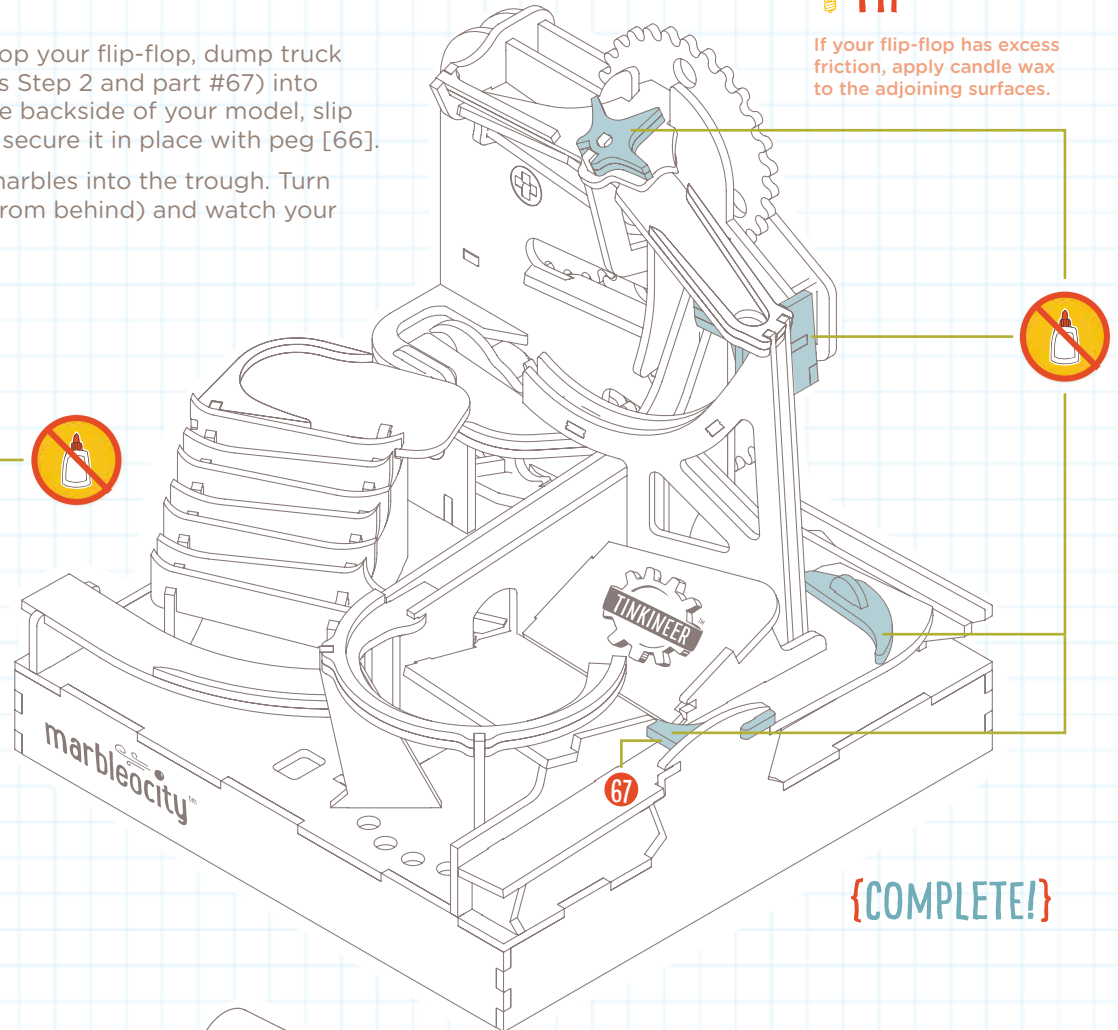

**{COMPLETE!}**

## OPTIONAL

### MOTORIZED YOUR COASTER

Did you know you can add an electric motor to drive this kit? If it wasn't included in the set you bought, check [tinkineer.com/products](http://tinkineer.com/products) for more information.

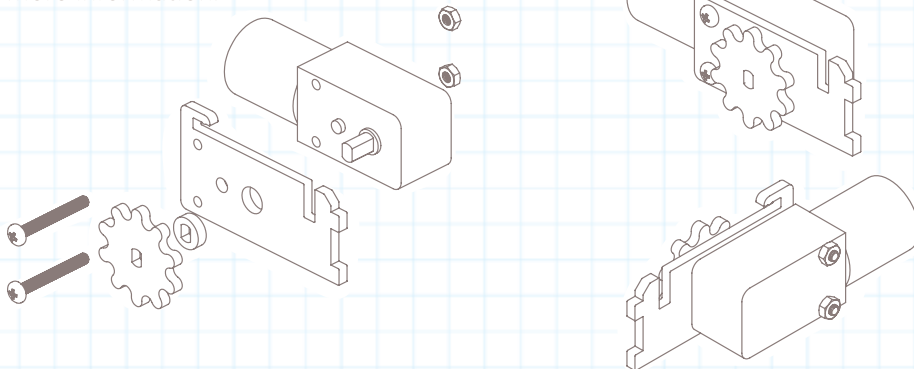

**{COMPLETE!}**

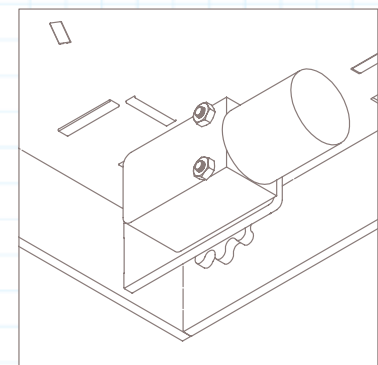

Shown installed below platform.

# WHERE TO FROM HERE?



## CONGRATULATIONS!

You've just built a complex, three-dimensional marble machine out of flat wooden parts and learned some physics in the process. Nice work!

## TELL US ABOUT IT! SHOW US!

We hope you enjoyed building/making with us. We'd love to see your Marbleocity Skate Park. Did you decorate your model? Where did you put it?



Share your photos and comments on our Tinkineer Facebook page and Instagram feed.



Tag us @tinkineer. Or contact us directly at [www.tinkineer.com/community](http://www.tinkineer.com/community).

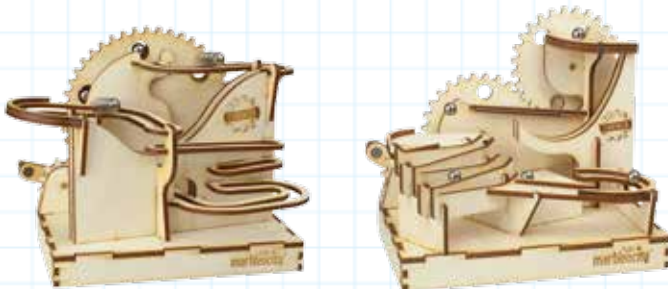

Good news, there are more kits available in the Marbleocity line! They come in multiple sizes. You've just built the Skate Park — one of the models from our full-size series.

The Marbleocity Mini Coaster and Mini Skate Park are pictured above. These stand alone and you can build them in any order! Mini kits are a fun 1-2 hour project.

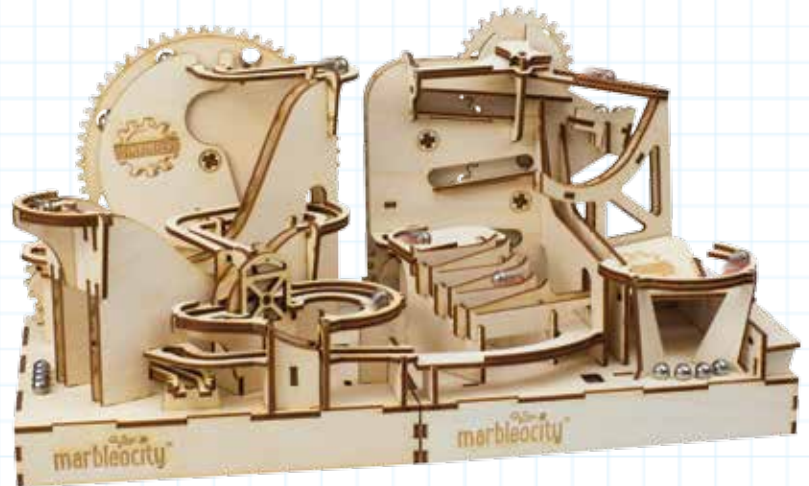

The real fun begins when you expand your marble empire by interconnecting the large kits! Build the full-size Dragon Coaster next. It will work as a stand-alone model but since you've already built the Skate Park you can link them together! Flip the diverters on your Skate Park and now marbles shuttle off to the Dragon Coaster and then return to the Skate Park after they've completed their coaster adventure (motor kits required).

That's right, the large models can be motorized! Motor kits are available separately and mount hidden beneath the platforms. Awesome!

VISIT [TINKINEER.COM/PRODUCTS](http://TINKINEER.COM/PRODUCTS) TO LEARN MORE. WE'LL SEE YOU THERE!



HE'S A TOTAL SMARTY PANTS

ADVENTURE AWAITS!  
{LET'S EXPLORE}

MAKERS HAVE MORE FUN

HE'S A TOTAL SMARTY PANTS

ADVENTURE AWAITS!  
{LET'S EXPLORE}

EVERYONE IS A TINKINEER

LEARNING IS THE BEST!

BUILD FUN

CUT IT, TRIM IT, GLUE IT, MAKE IT.

EVERYONE IS A TINKINEER

LEARNING IS THE BEST!

BUILD FUN

CUT IT, TRIM IT, GLUE IT, MAKE IT.

MAKERS HAVE MORE FUN

HE'S A TOTAL SMARTY PANTS

ADVENTURE AWAITS!  
{LET'S EXPLORE}

MAKERS HAVE MORE FUN

HE'S A TOTAL SMARTY PANTS

EVERYONE IS A TINKINEER

LEARNING IS THE BEST!

BUILD FUN

CUT IT, TRIM IT, GLUE IT, MAKE IT.

EVERYONE IS A TINKINEER

LEARNING IS THE BEST!

BUILD FUN

MAKERS HAVE MORE FUN

HE'S A TOTAL SMARTY PANTS

ADVENTURE AWAITS!  
{LET'S EXPLORE}

MAKERS HAVE MORE FUN

ADVENTURE AWAITS!  
{LET'S EXPLORE}

EVERYONE IS A TINKINEER

LEARNING IS THE BEST!

BUILD FUN

CUT IT, TRIM IT, GLUE IT, MAKE IT.

EVERYONE IS A TINKINEER

LEARNING IS THE BEST!

BUILD FUN

CUT IT, TRIM IT, GLUE IT, MAKE IT.

MAKERS HAVE MORE FUN

HE'S A TOTAL SMARTY PANTS

ADVENTURE AWAITS!  
{LET'S EXPLORE}

MAKERS HAVE MORE FUN

HE'S A TOTAL SMARTY PANTS

EVERYONE IS A TINKINEER

LEARNING IS THE BEST!

BUILD FUN

CUT IT, TRIM IT, GLUE IT, MAKE IT.

EVERYONE IS A TINKINEER

LEARNING IS THE BEST!

BUILD FUN

**⚠ WARNING:**  
**CHOKING HAZARD.**

Kit contains marbles and small parts.  
Not for children under 3 years old.



We wanna hear about all the fun you had!

Contact us at: Customer Service, 1400 E. Inman Pkwy.,  
Beloit, WI 53511 • [playmonster@playmonster.com](mailto:playmonster@playmonster.com) • 1-800-524-4263.  
For more fun, visit [playmonster.com](http://playmonster.com)

Copyright © 2017 PlayMonster LLC, 1400 E. Inman Pkwy., Beloit, WI 53511. Made in USA.  
All rights reserved. **Tinkineer**, **Marbleocity** and *Dragon Coaster* are trademarks of  
PlayMonster LLC. Parts and colors may vary from those shown.